

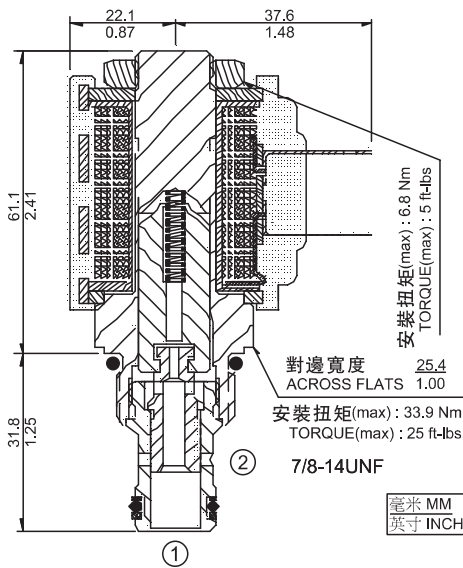

SV10-24 兩通常閉式錐閥 2-Way, Normally Closed



描述 DESCRIPTION

電磁驅動、2通常閉、直動滑閥式、液壓螺紋插裝閥，在低流量回路中用作雙向截止閥。

A solenoid-operated, 2-way, normally closed, direct-acting, spool-type, screw-in hydraulic cartridge valve, designed to operate as a bidirectional blocking valve in low flow circuits.

工作原理 OPERATION

斷電時，SV10-24 截止油液雙向流動。

通電后，插件的閥芯移動，從而允許油液雙向流動。

When de-energized, the SV10-24 blocks flow in both directions.

When energized, the cartridge's spool shifts to open the bidirectional flow path.

特性 SPECIFICATIONS

符號 SYMBOL	
工作壓力 PRESSURE	207 bar 3000 psi
流量 FLOW	38 L/min 10 gpm
內漏 LEAKAGE	≤ 82 ml/min at 207 bar (3000 psi)
密封材料/溫度範圍 SEAL MATERIAL/ TEMPERATURE	丁腈橡膠 -30°C ~ +100°C BUNA-N -20°F ~ +210°F 氟橡膠 -20°C ~ +150°C VITON -4°F ~ +330°F
線圈額定負載 COIL DUTY RATING	可在85%至115%的額定電壓範圍內連續工作 CONTINUOUS FROM 85% TO 115% OF NOMINAL VOLTAGE
過濾 FILTRATION	≤ 25 MICRONS
介質 FLUID	礦物油或具有潤滑作用的合成油 MINERAL OIL OR SYNTHETIC FLUID WITH LUBRICANT PROPERTIES
粘度 VISCOSITY	10.8~420 cSt 50~2000 ssu
閥孔 CAVITY	VC10-2

性能 (只針對插件) TYPICAL PERFORMANCE (Cartridge only)

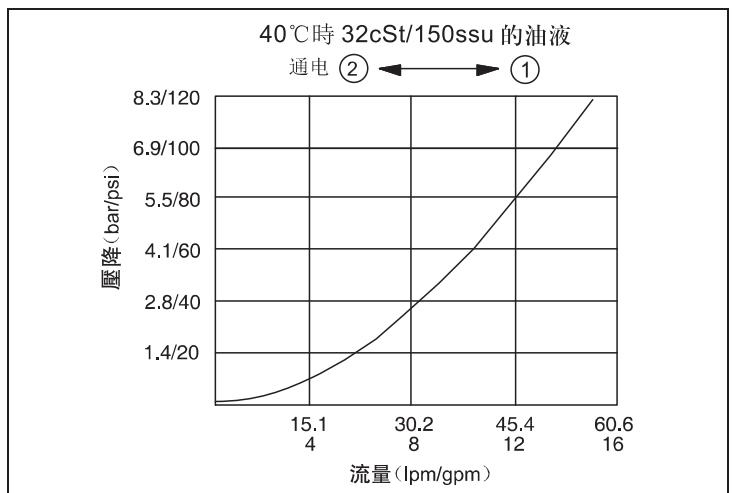

訂貨型號 HOW TO ORDER

SV10 - 24	-	-	-	-	-	-	-	-	-
選項 Option	無 None	S: 150μ 過濾網 150μ Screen	線圈電壓 Coil Voltage	0: 無線圈	12: DC 12V	24: DC 24V	115: AC 115V	230: AC 230V	線圈終端 Coil Termination
密封材料 Seal Material	N: 丁腈橡膠 Buna-N	V: 氟橡膠 Viton							DG: DIN43650
									DL: 導線 Leadwires
									DR: Deutsch DT04-2P
									AG: DIN43650
									AP: 1/2 英寸導線管 1/2 in. Conduit



兩通插裝閥閥孔 2-Way Cartridge Cavities

單位: mm

VC08-2

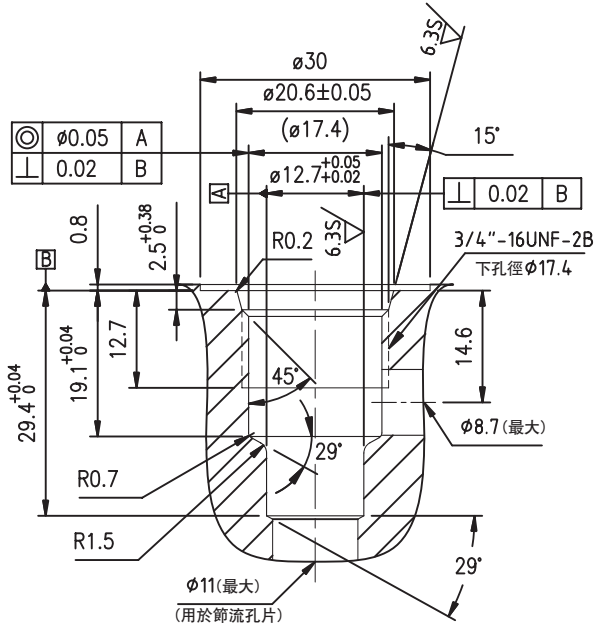

VC10-2

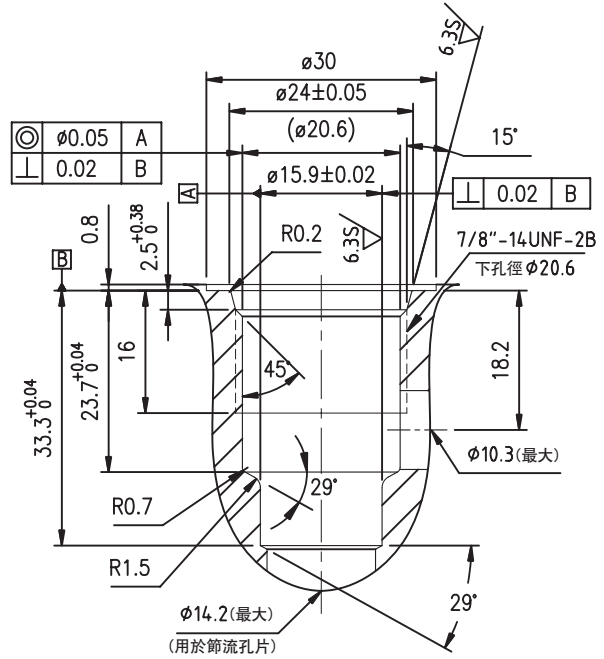

VC12-2

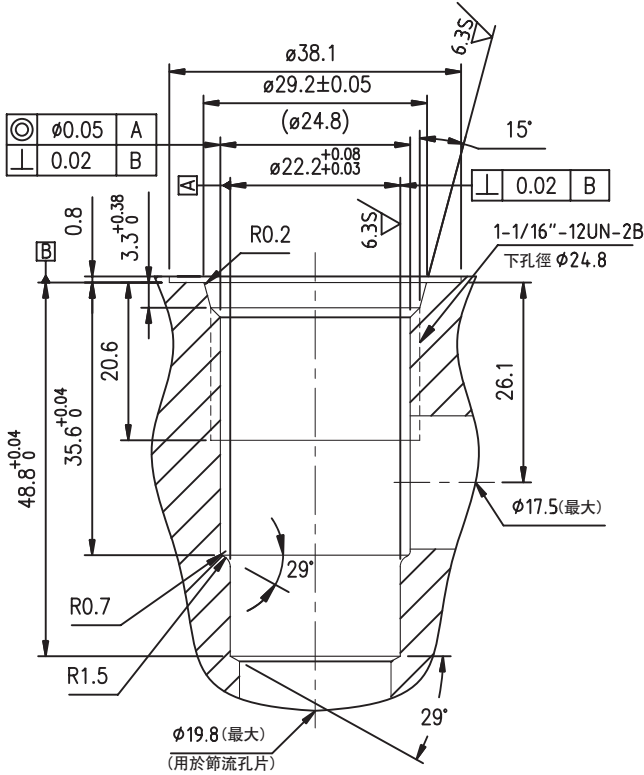

VC16-2

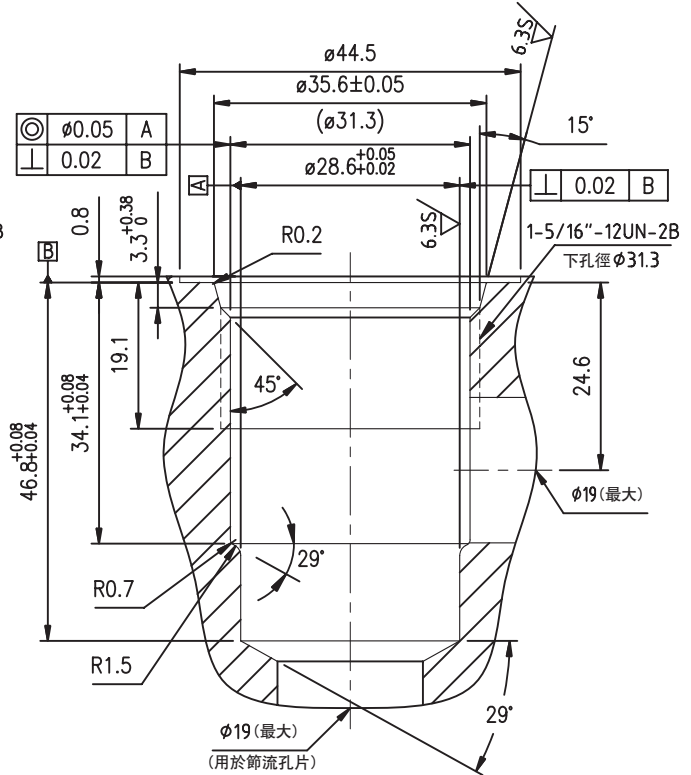

A
B
C
D
E
F
G
H
I
J
K

插裝閥閥孔