

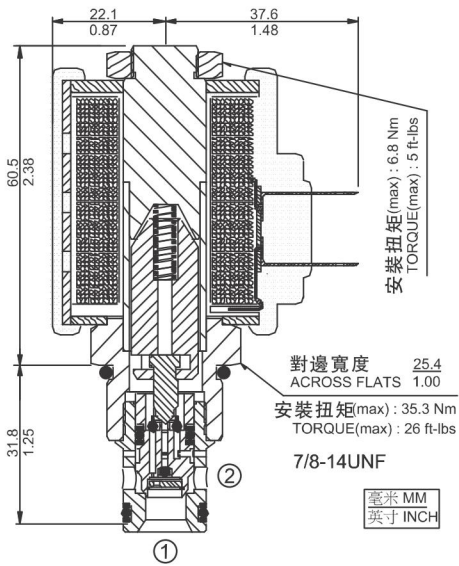

# ● SV10-28 兩通常閉式雙向截止座閥

## SV10-28 兩通常閉式雙向截止座閥 2-Way, N.C., Bidirectional Blocking, Poppet



### 描述 DESCRIPTION

電磁驅動、2通常閉、雙向截止、座閥式、液壓螺紋插裝閥，用于要求低泄漏的負載保持應用。

A solenoid-operated, 2-way, normally closed, bi-directional blocking, poppet-type, screw-in hydraulic cartridge valve, designed for low leakage in load-holding applications.

### 工作原理 OPERATION

斷電時，SV10-28 截止油液雙向流動。通電后，閥芯打開，允許油液雙向流動。

When de-energized, the SV10-28 blocks flow in both directions.

When energized, the valve's poppet opens on its seat, allowing flow in both directions.

### 特性

#### SPECIFICATIONS

符號 SYMBOL	
工作壓力 PRESSURE	240 bar 3500 psi
流量 FLOW	76 L/min 20 gpm
內漏 LEAKAGE	≤ 0.25 ml/min (5 drops/min) at 240 bar (3500 psi)
密封材料/溫度範圍 SEAL MATERIAL/ TEMPERATURE	丁腈橡膠 -30°C ~ +100°C BUNA-N -20°F ~ +210°F 氟橡膠 -20°C ~ +150°C VITON -4°F ~ +330°F
線圈額定負載 COIL DUTY RATING	可在85%至115%的額定電壓範圍內連續工作 CONTINUOUS FROM 85% TO 115% OF NOMINAL VOLTAGE
過濾 FILTRATION	≤ 25 MICRONS
介質 FLUID	礦物油或具有潤滑作用的合成油 MINERAL OIL OR SYNTHETIC FLUID WITH LUBRICANT PROPERTIES
粘度 VISCOSITY	10.8~420 cSt 50~2000 ssu
閥孔 CAVITY	VC10-2

### 性能 (只針對插件)

#### TYPICAL PERFORMANCE (Cartridge only)

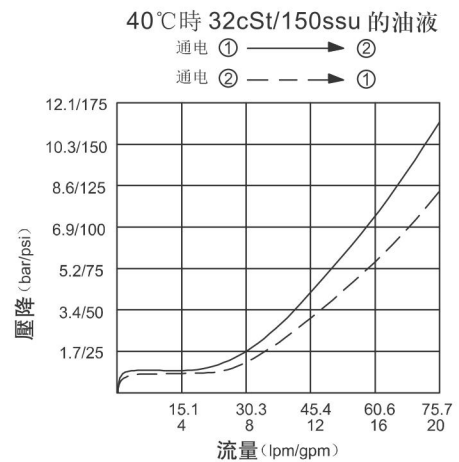

### 訂貨型號

#### HOW TO ORDER

#### SV10 - 28

選項 Option	線圈終端 Coil Termination
無 None	DG: DIN43650
S: 150μ 過濾網 150μ Screen	DL: 導線 Leadwires DR: Deutsch DT04-2P
	AG: DIN43650
	AP: 1/2 英寸導線管 1/2 in. Conduit
	線圈電壓 Coil Voltage
	0: 無線圈
密封材料 Seal Material	12: DC 12V
N: 丁腈橡膠 Buna-N	24: DC 24V
V: 氟橡膠 Viton	115: AC 115V
	230: AC 230V

雙向截止座閥



兩通插裝閥閥孔 2-Way Cartridge Cavities

單位: mm

VC08-2

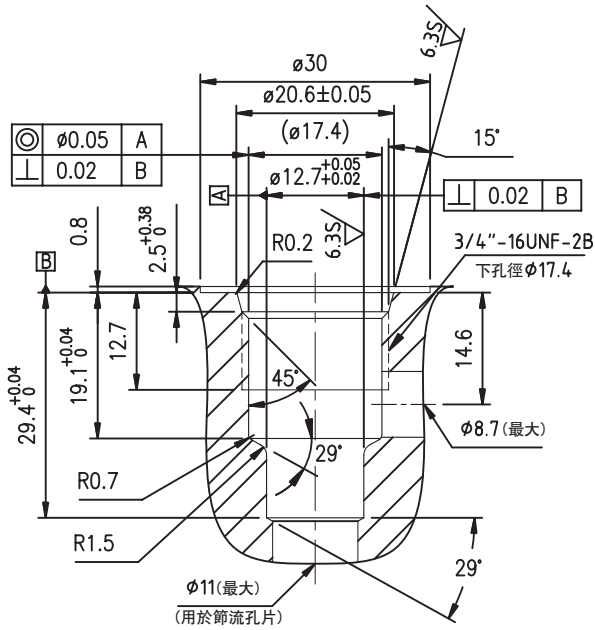

VC10-2

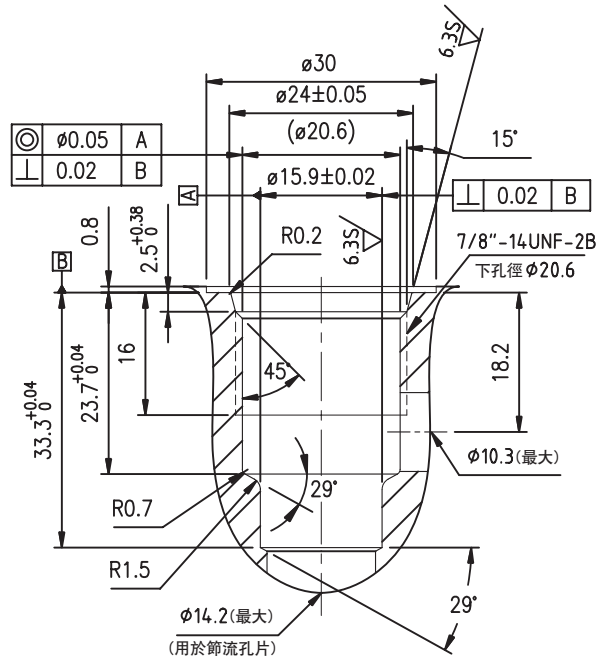

VC12-2

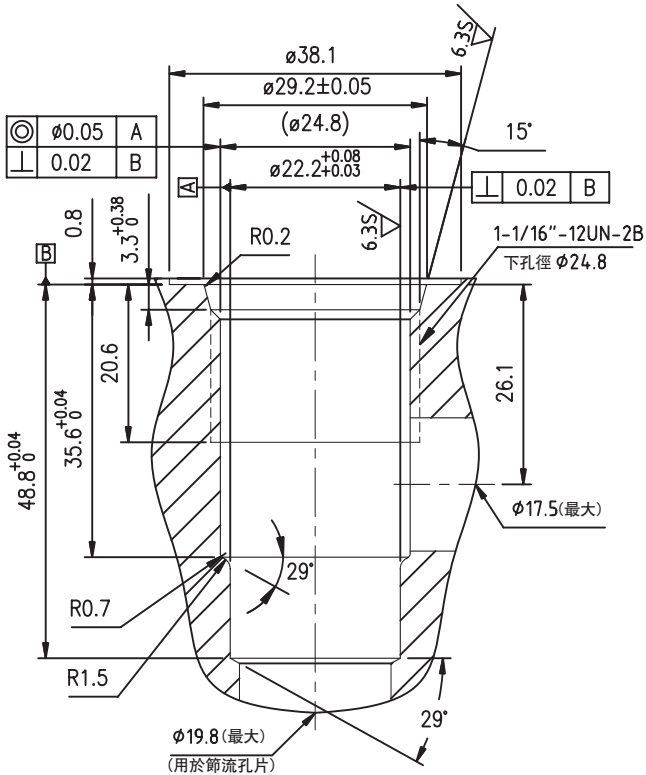

VC16-2

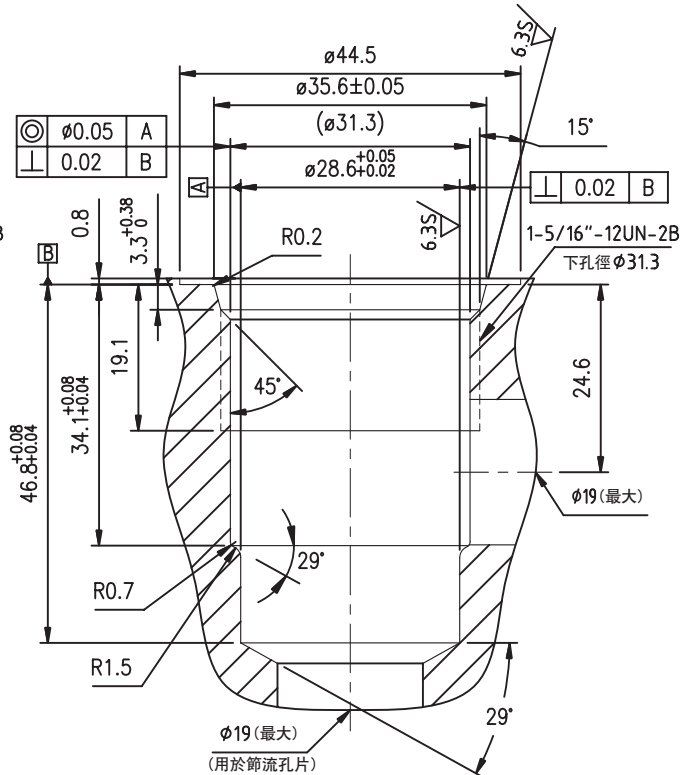

A  
B  
C  
D  
E  
F  
G  
H  
I  
J  
K

插裝閥閥孔