

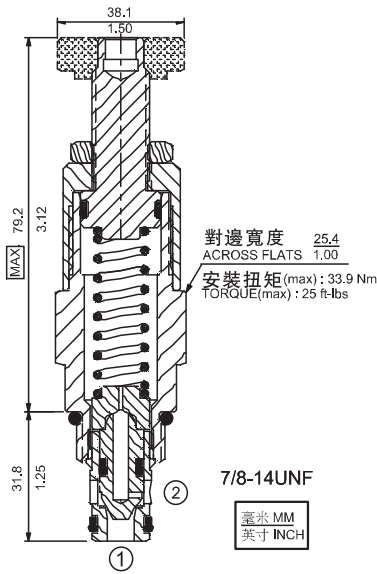

RV10-20 直動式溢流閥 Direct-Acting Poppet, Relief Valve



描述 DESCRIPTION

螺紋插裝、直動型、座閥式溢流閥，用作限壓裝置以保護液壓回路。
該閥適用於低洩漏，對負載變化快速響應的液壓回路。

A screw-in, cartridge-style, direct-acting, poppet-type, hydraulic relief valve intended for use as a pressure limiting device for common hydraulic circuit protection.

The cartridge offers fast response to load changes in typical hydraulic circuits requiring low internal leakage.

工作原理 OPERATION

RV10-20 型，常態下 ① 流向 ② 封閉，直到 ① 處受到足夠的液壓力克服彈簧力使閥芯離開閥座。

The RV10-20 blocks flow from ① to ② until sufficient pressure is present at ① to force the spring-opposed poppet from its seat.

特性 SPECIFICATIONS

性能 (只針對插件) TYPICAL PERFORMANCE (Cartridge only)

符號 SYMBOL	
工作壓力 PRESSURE	228 bar 3300 psi
流量 FLOW	38 L/min 10 gpm
內漏 LEAKAGE	≤ 0.25 ml/min (5 drops/min) 在80%的開啓壓力下， at 80% of nominal setting
密封材料/溫度範圍 SEAL MATERIAL/ TEMPERATURE	丁腈橡膠 -30°C ~ +100°C BUNA-N -20°F ~ +210°F 氟橡膠 -20°C ~ +150°C VITON -4°F ~ +330°F
過濾 FILTRATION	≤ 25 MICRONS
介質 FLUID	礦物油或具有潤滑作用的合成油 MINERAL OIL OR SYNTHETIC FLUID WITH LUBRICANT PROPERTIES
粘度 VISCOSITY	10.8~420 cSt 50~2000 ssu
閥孔 CAVITY	VC10-2

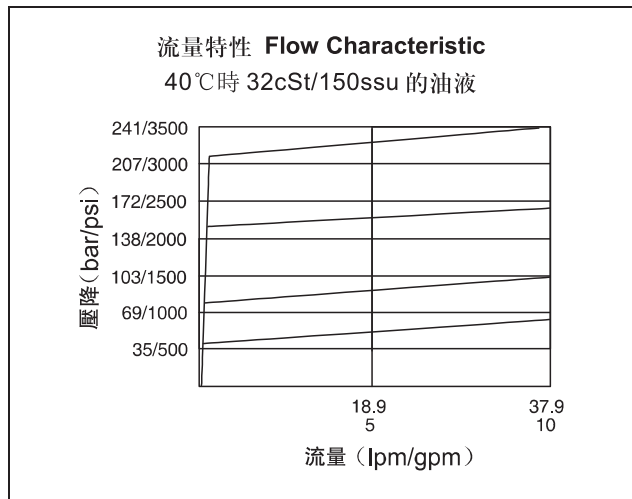

訂貨型號 HOW TO ORDER

RV10 - 20

調節機構 Adjusting Mechanism	調壓範圍 Spring Range
A: 1/4 寸內六角頭 1/4 in. Hex Allen Head	6: 3.5~41bar (50~600psi)
B: 直徑1-1/2 寸, 鋁合金手柄 1-1/2 in. Dia. Alum. Knob	12: 10~82bar (150~1200psi)
	23: 17~158bar (250~2300psi)
	33: 17~228bar (250~3300psi)
	密封材料 Seal Material
	N: 丁腈橡膠 Buna-N
	V: 氟橡膠 Viton

A
B
C
D
E
F
G
H
I
J
K

溢流閥



兩通插裝閥閥孔 2-Way Cartridge Cavities

單位: mm

VC08-2

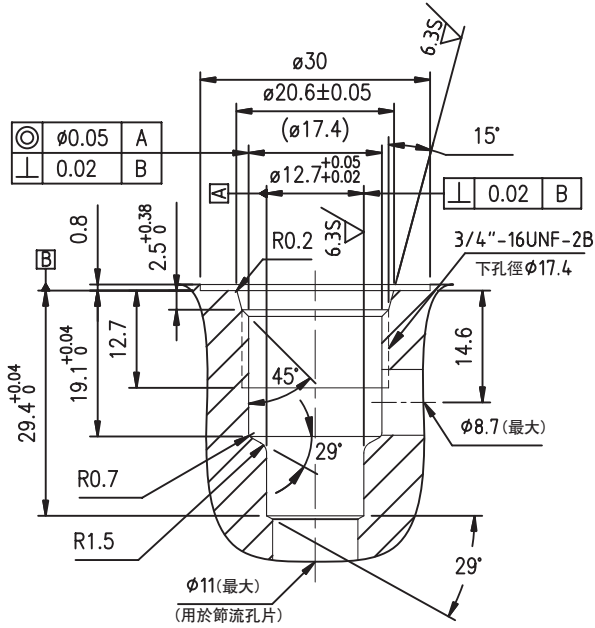

VC10-2

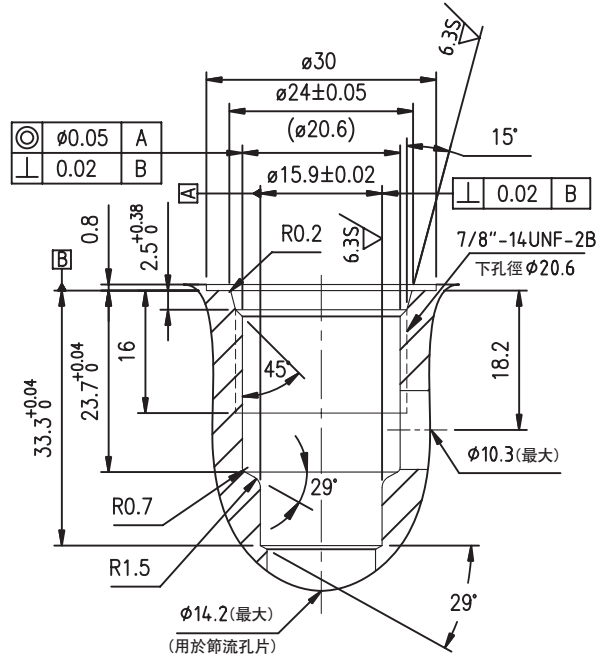

VC12-2

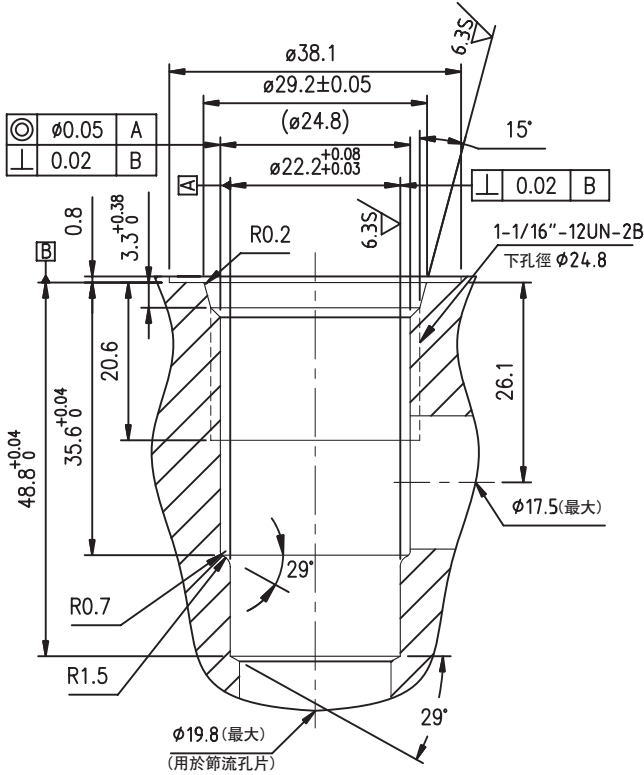

VC16-2

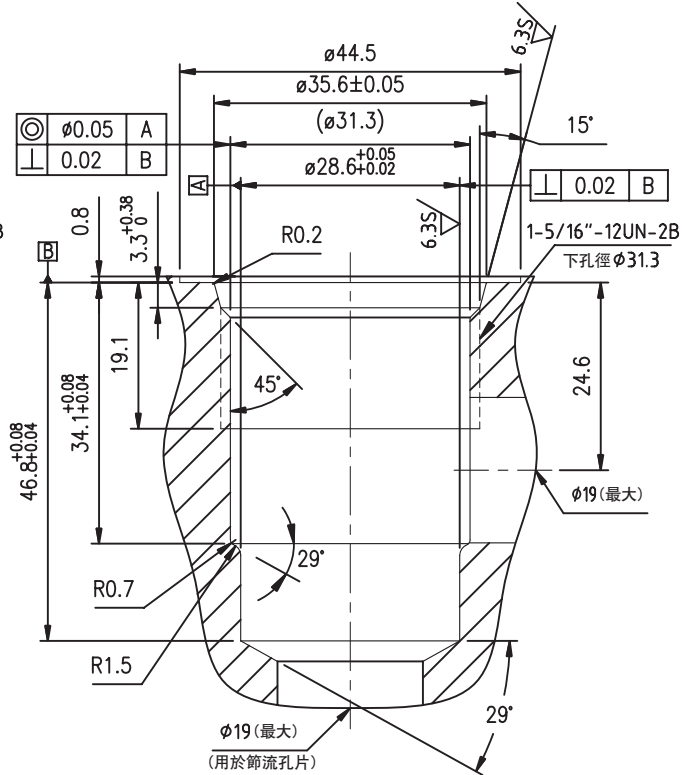

A
B
C
D
E
F
G
H
I
J
K

插裝閥閥孔