

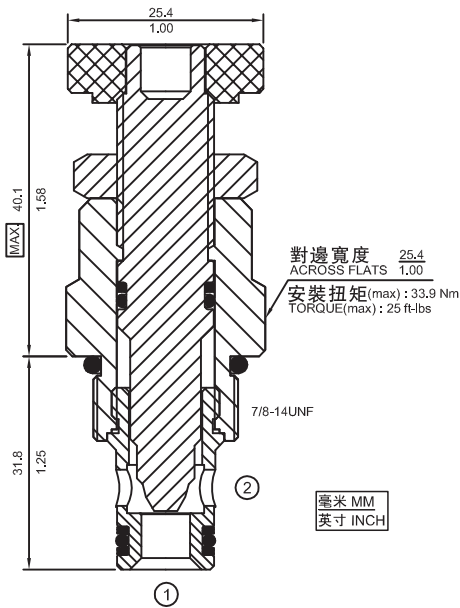

NV10-20 節流閥 Needle Valve



描述 DESCRIPTION

螺紋插裝式，可變節流孔，節流閥。

A screw-in, cartridge-style, variable orifice, hydraulic flow restrictor valve.

工作原理 OPERATION

NV10-20型，逆時針旋轉調節器時，可以使節流孔從完全鎖閉到完全打開。

The NV10-20 increases its orifice value from fully closed to fully open with counterclockwise adjustment rotation.

特性

SPECIFICATIONS

符號 SYMBOL	
工作壓力 PRESSURE	240 bar 3500 psi
流量 FLOW	56 L/min 15 gpm
內漏 LEAKAGE	≤ 0.25 ml/min (5 drops/min) at shut-off (關閉時)
密封材料/溫度範圍 SEAL MATERIAL/ TEMPERATURE	丁腈橡膠 -30°C ~ +100°C BUNA-N -20°F ~ +210°F 氟橡膠 -20°C ~ +150°C VITON -4°F ~ +330°F
過濾 FILTRATION	≤ 25 MICRONS
介質 FLUID	礦物油或具有潤滑作用的合成油 MINERAL OIL OR SYNTHETIC FLUID WITH LUBRICANT PROPERTIES
粘度 VISCOSITY	10.8~420 cSt 50~2000 ssu
閥孔 CAVITY	VC10-2

性能 (只針對插件)

TYPICAL PERFORMANCE (Cartridge only)

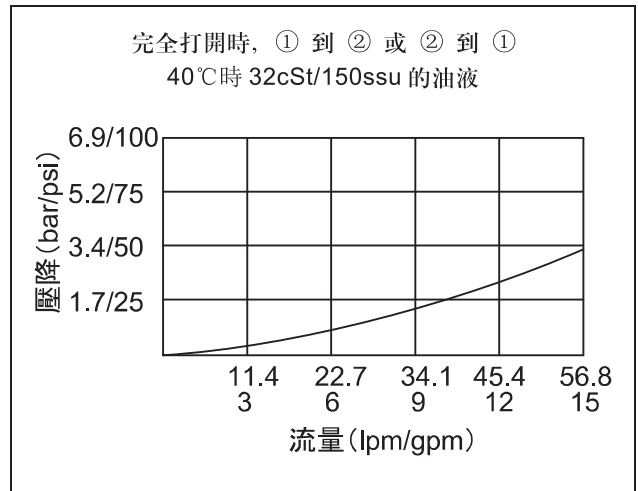

訂貨型號

HOW TO ORDER

NV10 - 20 -

- 密封材料
Seal Material
- N: 丁腈橡膠 Buna-N
- V: 氟橡膠 Viton
- 調節機構
Adjusting Mechanism
- A: 1/4 寸內六角頭
1/4 in. Hex Allen Head
- D: 頂部手柄，帶鎖緊螺帽
Top Knob with Lock Nut



兩通插裝閥閥孔 2-Way Cartridge Cavities

單位: mm

VC08-2

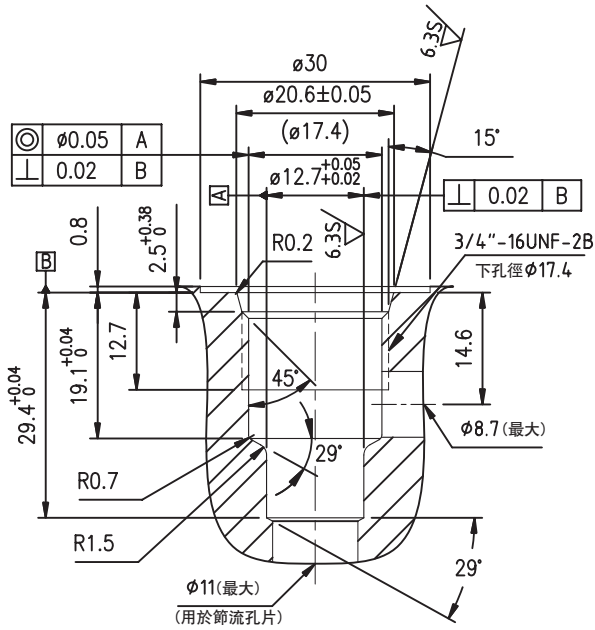

VC10-2

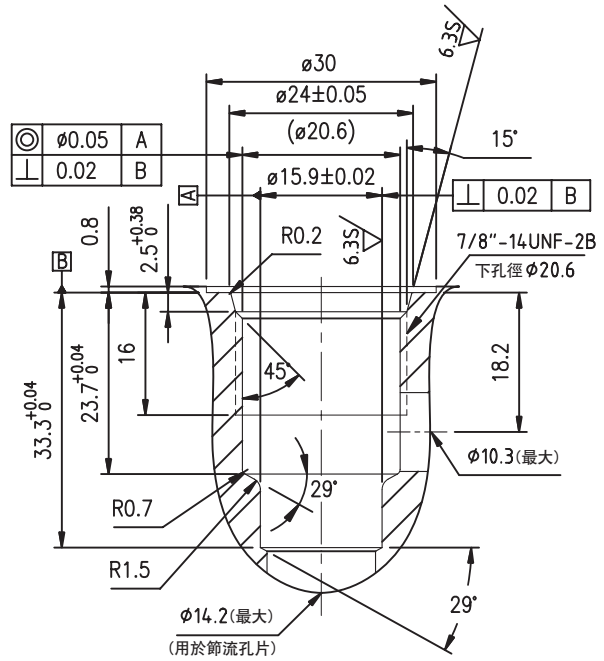

VC12-2

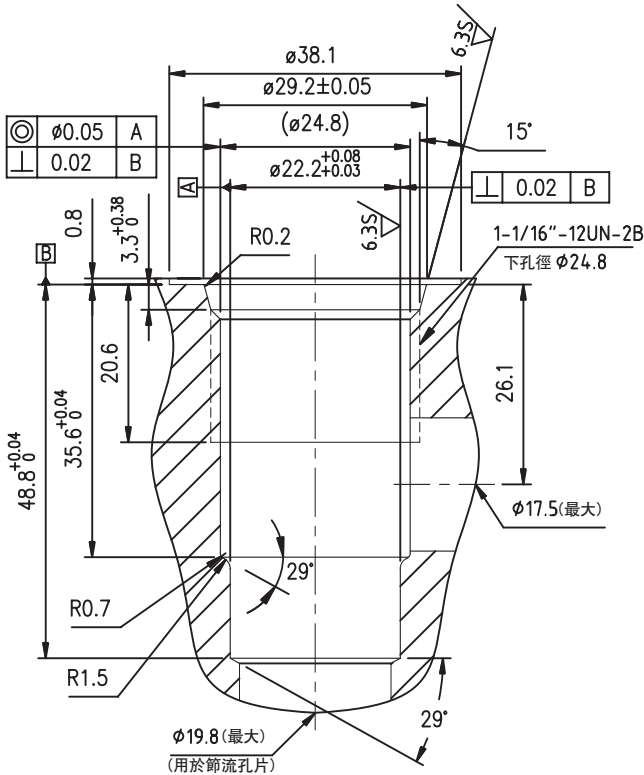

VC16-2

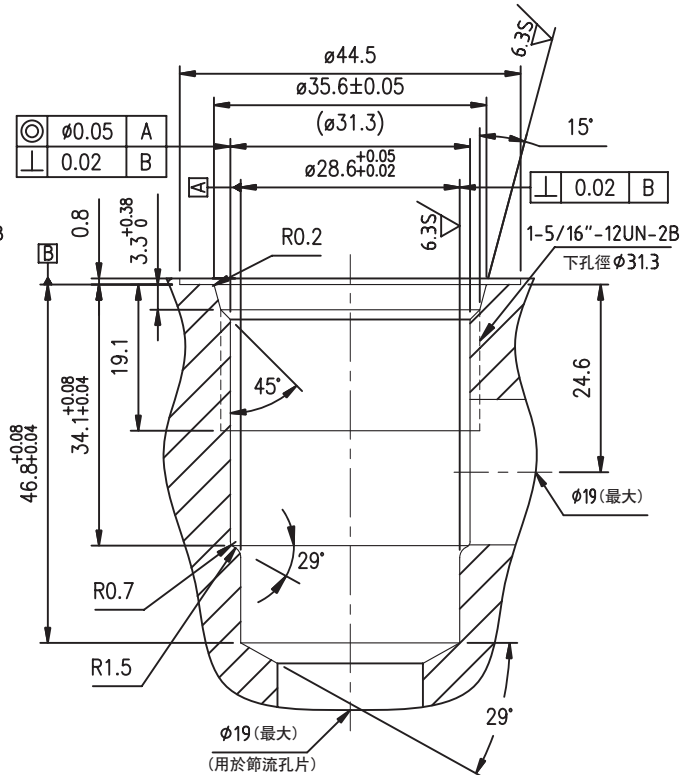

A
B
C
D
E
F
G
H
I
J
K

插裝閥閥孔