



NCV-01-NC-D\*\*-S 三通換向閥 3-Way, Spool

描述 DESCRIPTION

電磁驅動、3通、直動閥芯式、螺紋液壓方向閥。主要安裝於工程機械多路控制閥或變量泵的先導控制油路當中，用於控制先導回路的導通和切斷或者起壓和卸荷。

A solenoid-operated, 3-way, direct-acting, spool-type, screw-in hydraulic directional valve, mainly installed on the pilot control oil circuit of multiple unit valve or variable pump in the engineering machinery, for controlling the on and off of the pilot circuit or pressure and unloading.

工作原理 OPERATION

斷電時，允許油液從 ① 流向 ②，而在 ③ 處截止。通電后，插件的閥芯移動，從而接通 ③ 流向 ①，而在 ② 處截止。在 ① 可能容許的背壓小於13.7Mpa。When de-energized, the valve allows flow from ① to ②, while blocking flow at ③. When energized, the cartridge's spool shifts to open from ③ to ①, while blocking at ②. While ① may be permissible back pressure is less than 13.7Mpa.

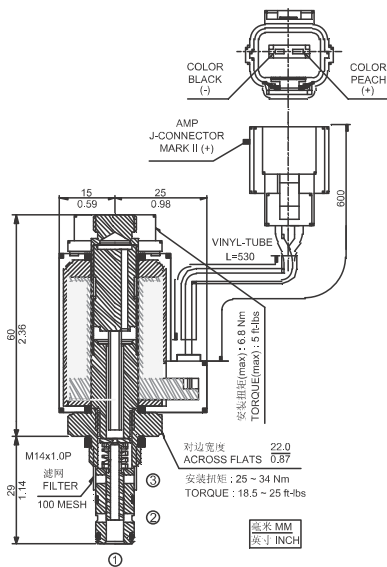

特性 SPECIFICATIONS

符號 SYMBOL	
工作壓力 PRESSURE	206 bar 3000 psi
最大壓力 MAX. PRESSURE	260 bar 3770 psi
流量 FLOW	3 L/min 0.82 gpm
內漏 LEAKAGE	≤ 15 ml/min at 98 bar (1400 psi)
工作油溫 OIL TEMP.	-20°C ~ +100°C -4°F ~ +210°F
粘度 VISCOSITY	5~500 cSt 23~2300 ssu
線圈額定負載 COIL DUTY RATING	可在85%至110%的額定電壓範圍內連續工作 CONTINUOUS FROM 85% TO 110% OF NOMINAL VOLTAGE
過濾 FILTRATION	≤ 25 MICRONS
介質 FLUID	礦物油或具有潤滑作用的合成油 MINERAL OIL OR SYNTHETIC FLUID WITH LUBRICANT PROPERTIES
閥孔 CAVITY	NCV-01

特性 SPECIFICATIONS

壓力降 PRESSURE DROP	≤ 0.5 bar (7 psi) at 2 L/min (0.55 gpm)
響應時間 RESPONS TIME	< 60 msec
浪涌電壓 SURGE VOLTAGE	< 1V (內建二極體) (DIODE BUILT-IN)
耐水性能 WATER PROOF	JIS D0203 S2
耐震性能 VIBRATION-RESISTING	JIS D1601 3類 B種 階段 45
電氣回路 ELECTRIC CIRCUIT	

訂貨型號 HOW TO ORDER

NCV - 01 - NC - D	- S
	線圈電壓 Coil Voltage
	0: 無線圈
	12: DC 12V
	24: DC 24V

換向閥