

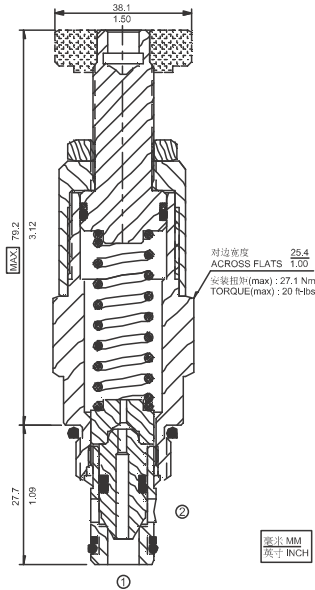

RV08-22 差動式溢流閥 Differential Area Poppet, Relief Valve



描述 DESCRIPTION

螺紋插裝,直動型,差動型溢流閥,作為壓力限制裝置用于較苛刻的液壓回路,要求低滯后和極小內泄漏。該閥在常規液壓回路提供平滑過渡以響應負載壓力變化。

A screw-in, cartridge-style, direct-acting, differential area, poppet-type hydraulic relief valve for use as a pressure limiting device in more demanding hydraulic circuits, requiring low hysteresis and low internal leakage. The cartridge offers smooth transition in response to load changes in common hydraulic circuits.

工作原理 OPERATION

RV08-22 型, 常態下②流向①封閉,直到②處受到足夠的液壓力克服彈簧力使閥芯離開閥座。

The RV08-22 blocks flow from ② to ① until sufficient pressure is present at ② to force the spring-opposed poppet from its seat.

特性 SPECIFICATIONS

性能 (只針對插件) TYPICAL PERFORMANCE (Cartridge only)

符號 SYMBOL	
工作壓力 PRESSURE	220 bar 3200 psi
流量 FLOW	30 L/min 8 gpm
內漏 LEAKAGE	≤ 0.25 ml/min (5 drops/min) 在85%的開啓壓力下, at 85% of nominal setting
密封材料/溫度範圍 SEAL MATERIAL/ TEMPERATURE	丁腈橡膠 -30°C ~ +100°C BUNA-N -20°F ~ +210°F 氟橡膠 -20°C ~ +150°C VITON -4°F ~ +330°F
過濾 FILTRATION	≤ 25 MICRONS
介質 FLUID	礦物油或具有潤滑作用的合成油 MINERAL OIL OR SYNTHETIC FLUID WITH LUBRICANT PROPERTIES
粘度 VISCOSITY	10.8~420 cSt 50~2000 ssu
閥孔 CAVITY	VC08-2

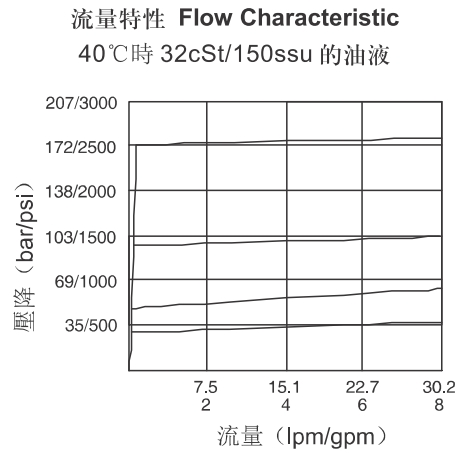

訂貨型號 HOW TO ORDER

RV08 - 22

調節機構 Adjusting Mechanism	密封材料 Seal Material
A: 1/4 寸內六角頭 1/4 in. Hex Allen Head	N: 丁腈橡膠 Buna-N
B: 直徑1-1/2 寸, 鋁合金手柄 1-1/2 in. Dia. Alum. Knob	V: 氟橡膠 Viton

調壓範圍
Spring Range

- 4: 3.5~27.5bar (50~400psi)
- 9: 7~65bar (100~900psi)
- 17: 7~117bar (100~1700psi)
- 32: 17~220bar (250~3200psi)

溢流閥