

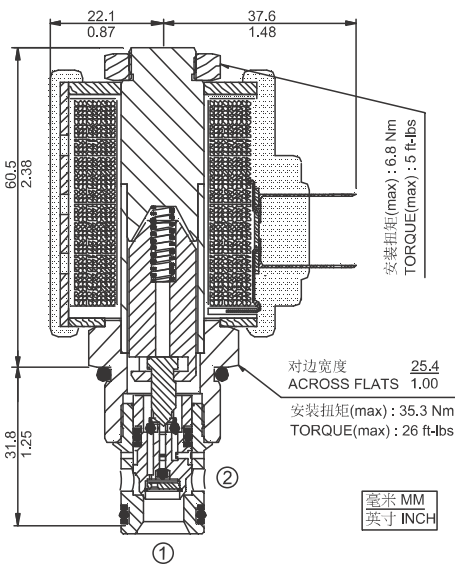

● SV10-28 兩通常開式雙向截止座閥

SV10-28 兩通常開式雙向截止座閥 2-Way, N.C., Bidirectional Blocking, Poppet



描述 DESCRIPTION

電磁驅動、2通常閉、雙向截止、座閥式、液壓螺紋插裝閥，用于要求低泄漏的負載保持應用。

A solenoid-operated, 2-way, normally closed, bi-directional blocking, poppet-type, screw-in hydraulic cartridge valve, designed for low leakage in load-holding applications.

工作原理 OPERATION

斷電時，SV10-28 截止油液雙向流動。通電后，閥芯打開，允許油液雙向流動。

When de-energized, the SV10-28 blocks flow in both directions.

When energized, the valve's poppet opens on its seat, allowing flow in both directions.

特性 SPECIFICATIONS

符號 SYMBOL	
工作壓力 PRESSURE	240 bar 3500 psi
流量 FLOW	76 L/min 20 gpm
內漏 LEAKAGE	≤ 0.25 ml/min (5 drops/min) at 240 bar (3500 psi)
密封材料/溫度範圍 SEAL MATERIAL/ TEMPERATURE	丁腈橡膠 -30°C ~ +100°C BUNA-N -20°F ~ +210°F 氟橡膠 -20°C ~ +150°C VITON -4°F ~ +330°F
線圈額定負載 COIL DUTY RATING	可在85%至115%的額定電壓範圍內連續工作 CONTINUOUS FROM 85% TO 115% OF NOMINAL VOLTAGE
過濾 FILTRATION	≤ 25 MICRONS
介質 FLUID	礦物油或具有潤滑作用的合成油 MINERAL OIL OR SYNTHETIC FLUID WITH LUBRICANT PROPERTIES
粘度 VISCOSITY	10.8~420 cSt 50~2000 ssu
閥孔 CAVITY	VC10-2

性能（只針對插件） TYPICAL PERFORMANCE (Cartridge only)

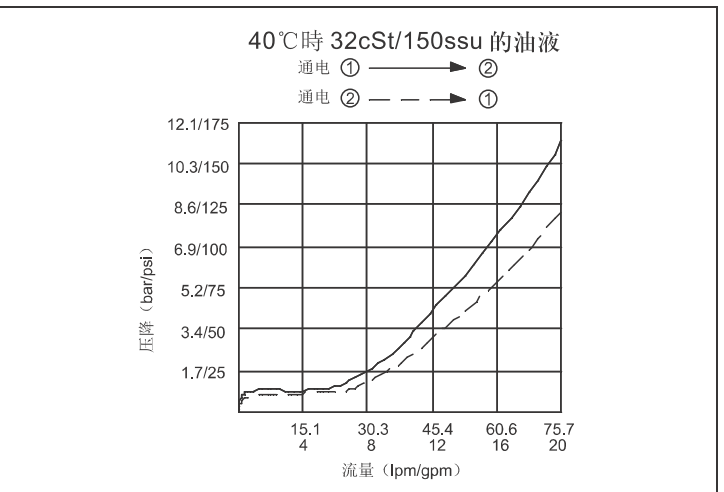

訂貨型號 HOW TO ORDER

SV10 - 28					
選項 Option				線圈終端 Coil Termination	
無 None				DG: DIN43650	
S: 150μ 過濾網 150μ Screen				DL: 導線 Leadwires	
				DR: Deutsch DT04-2P	
				AG: DIN43650	
			線圈電壓 Coil Voltage	AP: 1/2 英寸導線管 1/2 in. Conduit	
			0: 無線圈		
密封材料 Seal Material			12: DC 12V		
N: 丁腈橡膠 Buna-N			24: DC 24V		
V: 氟橡膠 Viton			115: AC 115V		
			230: AC 230V		

雙向截止座閥