

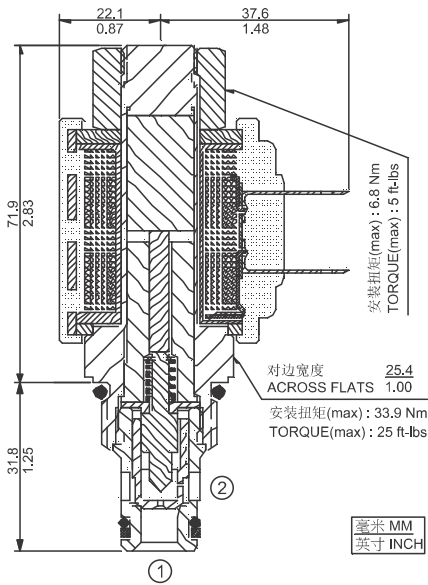

# SV10-21 兩通常開式錐閥

## SV10-21 兩通常開式錐閥 2-Way, Normally Open, Poppet



### 描述 DESCRIPTION

電磁驅動、2 通常開、導控座閥式、液壓螺紋插裝閥，用于要求低泄漏的負載保持應用。

A solenoid-operated, 2-way, normally open, piloted poppet-type, screw-in hydraulic cartridge valve designed for low leakage in load-holding applications.

### 工作原理 OPERATION

斷電時，SV10-21允許油液從②流向①，在此工况下，油液從①流向②的流動將受到巨大限制。

通電后，閥芯關閉閥座，從而截止油液從②流向①。在此工况下，在①口的壓力克服電磁力（所需壓力為3.4至10.3 bar [ 50至150 psi ]）后，插裝閥允許油液從①流向②。

When de-energized, the SV10-21 allows flow from ② to ①. Flow from ① to ② is severely restricted in this mode.

When energized, the valve's poppet closes on its seat, blocking flow from ② to ①. In this mode the cartridge will allow ① to ② flow after overcoming the solenoid force (requires 3.4 to 10.3 bar [ 50 to 150 psi ]).

### 特性

#### SPECIFICATIONS

符號 SYMBOL	
工作壓力 PRESSURE	207 bar 3000 psi
流量 FLOW	57 L/min 15 gpm
內漏 LEAKAGE	≤ 0.15 ml/min ( 3 drops/min ) at 207 bar (3000 psi)
密封材料/溫度範圍 SEAL MATERIAL/ TEMPERATURE	丁腈橡膠 -30°C ~ +100°C BUNA-N -20°F ~ +210°F 氟橡膠 -20°C ~ +150°C VITON -4°F ~ +330°F
線圈額定負載 COIL DUTY RATING	可在85%至115%的額定電壓範圍內連續工作 CONTINUOUS FROM 85% TO 115% OF NOMINAL VOLTAGE
過濾 FILTRATION	≤ 25 MICRONS
介質 FLUID	礦物油或具有潤滑作用的合成油 MINERAL OIL OR SYNTHETIC FLUID WITH LUBRICANT PROPERTIES
粘度 VISCOSITY	10.8~420 cSt 50~2000 ssu
閥孔 CAVITY	VC10-2

### 性能（只針對插件）

#### TYPICAL PERFORMANCE (Cartridge only)

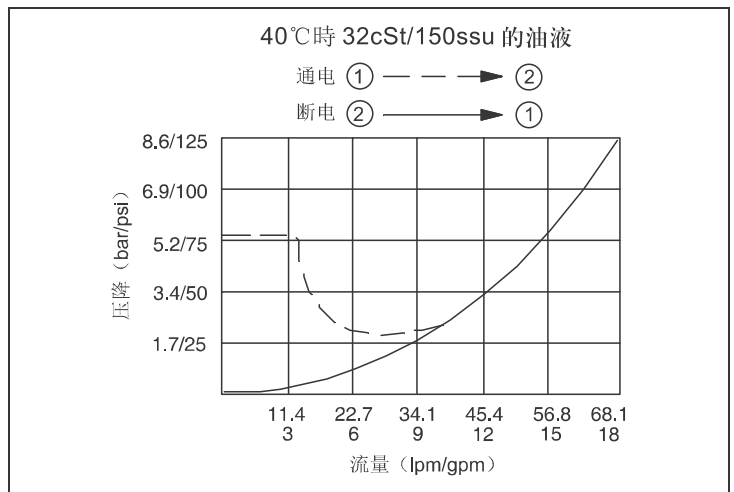

### 訂貨型號

#### HOW TO ORDER

SV10 - 21				
選項 Option	無 None	S: 150μ 過濾網 150μ Screen	線圈電壓 Coil Voltage	線圈終端 Coil Termination
密封材料 Seal Material	N: 丁腈橡膠 Buna-N	V: 氟橡膠 Viton	0: 無線圈	DG: DIN43650
			12: DC 12V	DL: 導線 Leadwires
			24: DC 24V	DR: Deutsch DT04-2P
			115: AC 115V	AG: DIN43650
			230: AC 230V	AP: 1/2 英寸導線管 1/2 in. Conduit

錐閥