

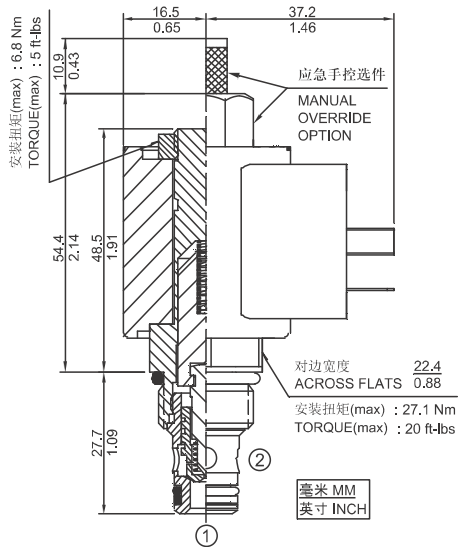

● SV08-20 兩通常閉式錐閥

SV08-20 兩通常閉式錐閥 2-Way, Normally Closed, Poppet



描述 DESCRIPTION

電磁驅動、2 通常閉、導控座閥式、液壓螺紋插裝閥，用作低流量油路中的截止或負載保持設備。

A solenoid-operated, 2-way, normally closed, piloted poppet-type, screw-in hydraulic cartridge valve, intended to act as a blocking or load-holding device for low flow circuits.

工作原理 OPERATION

斷電時，SV08-20 用作單向閥，允許油液從①流向②，同時截止油液從②流向①。通電后，插裝閥的閥芯提升，從而打開從②流向①的油液通道。在此工況下，油液從①流向②的流動將受到巨大限制。

When de-energized, the SV08-20 acts as a check valve, allowing flow from ① to ②, while blocking flow from ② to ①.

When energized, the cartridge's poppet lifts to open the ② to ① flow path. In this mode, flow from ① to ② is severely restricted.

特性 SPECIFICATIONS

性能（只針對插件） TYPICAL PERFORMANCE (Cartridge only)

符號 SYMBOL	
工作壓力 PRESSURE	207 bar 3000 psi
流量 FLOW	23 L/min 6 gpm
內漏 LEAKAGE	≤ 0.15 ml/min (3 drops/min) at 207 bar (3000 psi)
密封材料/溫度範圍 SEAL MATERIAL/ TEMPERATURE	丁腈橡膠 -30°C ~ +100°C BUNA-N -20°F ~ +210°F 氟橡膠 -20°C ~ +150°C VITON -4°F ~ +330°F
線圈額定負載 COIL DUTY RATING	可在85%至115%的額定電壓範圍內連續工作 CONTINUOUS FROM 85% TO 115% OF NOMINAL VOLTAGE
過濾 FILTRATION	≤ 25 MICRONS
介質 FLUID	礦物油或具有潤滑作用的合成油 MINERAL OIL OR SYNTHETIC FLUID WITH LUBRICANT PROPERTIES
粘度 VISCOSITY	10.8~420 cSt 50~2000 ssu
閥孔 CAVITY	VC08-2

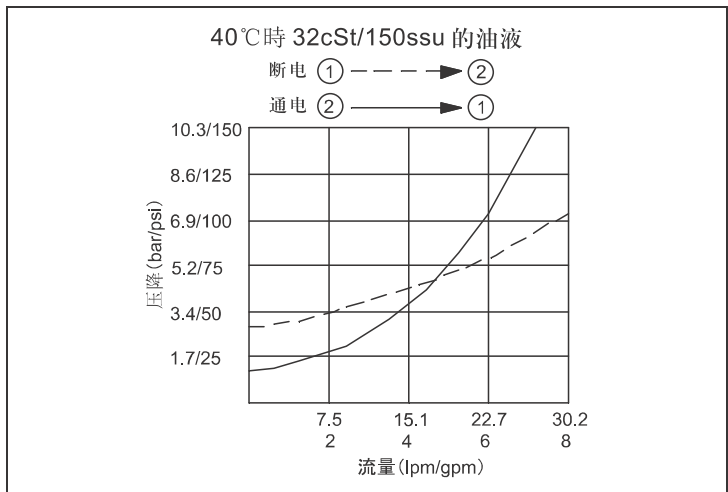

訂貨型號 HOW TO ORDER

SV08 - 20					
選項 Option	無 None	S: 150μ 過濾網 150μ Screen	M: 應急手控 Manual Override	線圈終端 Coil Termination	DG: DIN43650
密封材料 Seal Material	N: 丁腈橡膠 Buna-N	V: 氟橡膠 Viton	線圈電壓 Coil Voltage	0: 無線圈	12: DC 12V
				24: DC 24V	
				115: AC 115V	
				230: AC 230V	
				AG: DIN43650	
				DL: 導線 Leadwires	
				DR: Deutsch DT04-2P	
				AP: 1/2 英寸導線管 1/2 in. Conduit	

A
B
C
D
E
F
G
H

I
J
K

錐閥