

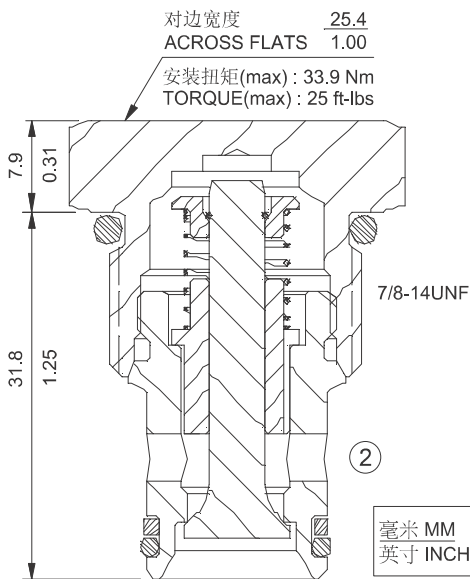

CV10-21 單向閥 Check Valve



描述 DESCRIPTION

螺紋插裝式液壓單向閥，用作單向截止或負載保持設備。

A screw-in, cartridge-style, hydraulic check valve for use as a blocking or load-holding device.

工作原理 OPERATION

CV10-21 允許油液從 ② 流向 ①，同時截止油液反向流動。全導向閥芯在復位彈簧壓力的作用下關閉閥口直到 ② 處壓力足夠大時打開 ①。

The CV10-21 allows flow passage from ② to ①, while blocking flow from ① to ②. The cartridge has a fully guided check which is spring-biased closed until sufficient pressure is applied at ② to open to ①.

特性

SPECIFICATIONS

| | |
|--|---|
| 符號 SYMBOL | |
| 工作壓力 PRESSURE | 240 bar 3500 psi |
| 流量 FLOW | 56 L/min 15 gpm |
| 內漏 LEAKAGE | ≤ 0.25 ml/min (5 drops/min) at 207 bar (3000 psi) |
| 密封材料/溫度範圍 SEAL MATERIAL/ TEMPERATURE | 丁腈橡膠 -30°C ~ +100°C BUNA-N -20°F ~ +210°F 氟橡膠 -20°C ~ +150°C VITON -4°F ~ +330°F |
| 過濾 FILTRATION | ≤ 25 MICRONS |
| 介質 FLUID | 礦物油或具有潤滑作用的合成油 MINERAL OIL OR SYNTHETIC FLUID WITH LUBRICANT PROPERTIES |
| 粘度 VISCOSITY | 10.8~420 cSt 50~2000 ssu |
| 閥孔 CAVITY | VC10-2 |

性能 (只針對插件)

TYPICAL PERFORMANCE (Cartridge only)

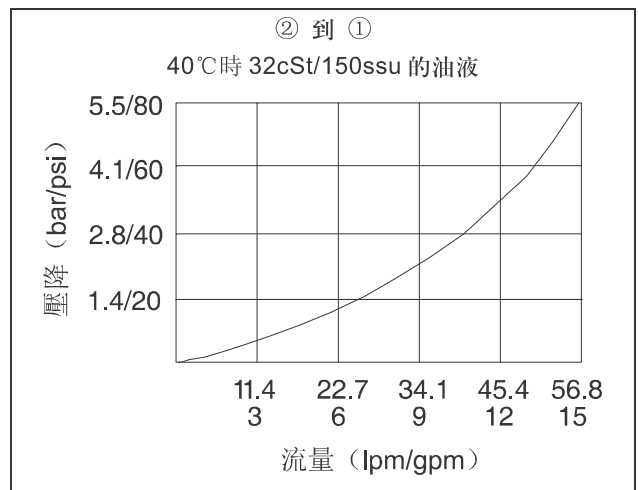

訂貨型號

HOW TO ORDER

CV10 - 21 - -

密封材料
Seal Material
N: 丁腈橡膠 Buna-N
V: 氟橡膠 Viton

開啓壓力
Cracking Pressure
05: 0.35 bar (5psi)
30: 2.1 bar (30psi)
50: 3.5 bar (50psi)