

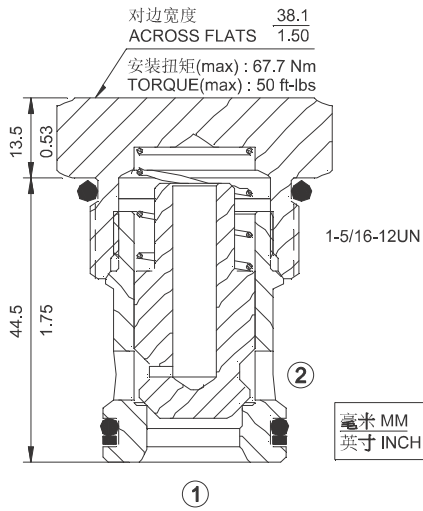

CV16-20 單向閥 Check Valve



描述 DESCRIPTION

螺紋插裝式液壓單向閥，用作單向截止或負載保持設備。

A screw-in, cartridge-style, hydraulic check valve for use as a blocking or load-holding device.

工作原理 OPERATION

CV16-20 允許油液從 ① 流向 ②，同時截止油液反向流動。全導向閥芯在復位彈簧壓力的作用下關閉閥口直到 ① 處壓力足夠大時打開 ②

The CV16-20 allows flow passage from ① to ②, while normally blocking oil flow in the opposite direction.

The cartridge has a fully guided check which is spring-biased closed until sufficient pressure is applied at ① to open to ②.

特性

SPECIFICATIONS

符號 SYMBOL	
工作壓力 PRESSURE	240 bar 3500 psi
流量 FLOW	151 L/min 40 gpm
內漏 LEAKAGE	≤ 0.25 ml/min (5 drops/min) at 240 bar (3500 psi)
密封材料/溫度範圍 SEAL MATERIAL/ TEMPERATURE	丁腈橡膠 -30°C ~ +100°C BUNA-N -20°F ~ +210°F 氟橡膠 -20°C ~ +150°C VITON -4°F ~ +330°F
過濾 FILTRATION	≤ 25 MICRONS
介質 FLUID	礦物油或具有潤滑作用的合成油 MINERAL OIL OR SYNTHETIC FLUID WITH LUBRICANT PROPERTIES
粘度 VISCOSITY	10.8~420 cSt 50~2000 ssu
閥孔 CAVITY	VC16-2

性能 (只針對插件)

TYPICAL PERFORMANCE (Cartridge only)

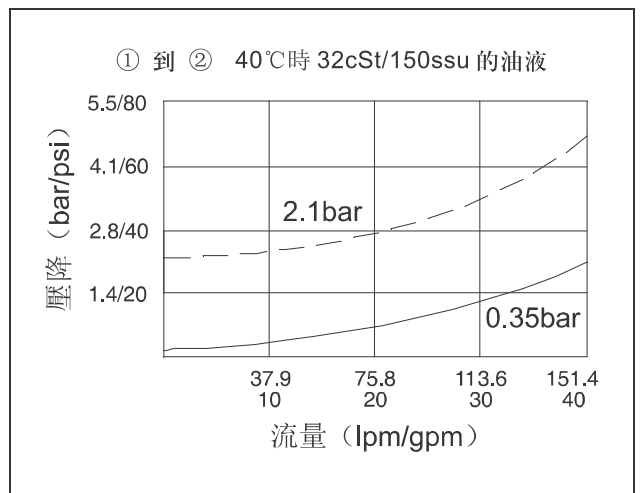

訂貨型號

HOW TO ORDER

CV16 - 20 -

密封材料 Seal Material	N: 丁腈橡膠 Buna-N V: 氟橡膠 Viton
開啓壓力 Cracking Pressure	05: 0.35 bar (5psi) 30: 2.1 bar (30psi) 50: 3.5 bar (50psi)